

Primex XR 72MHz Synchronized Time Solution

# XR 1 Watt Transmitter - Internal Antenna Install & User Guide



## Legal Notice

Copyright ©2018 Primex, Inc. All rights reserved.

Printed in the USA.

Information in this document is subject to change without notice. Software described in this document is furnished under a license agreement or nondisclosure agreement. The software may be used or copied only in accordance with the terms of those agreements.

No part of this publication may be reproduced, stored in a retrieval system, or transmitted in any form or by any means, electronic, mechanical or otherwise, for any purpose, without the prior written permission of Primex, Inc.

## Primex, Inc.

Primex is a leading provider of synchronized time and environmental monitoring solutions. Our solutions automate and maintain facility compliance, increase efficiencies, enhance safety and reduce risk for organizations in the healthcare, education, manufacturing and government vertical markets.

Worldwide Headquarters

965 Wells Street, Lake Geneva, WI 53147

Phone: 1-262-729-4853 | email: [info@primexinc.com](mailto:info@primexinc.com) | [www.primexinc.com](http://www.primexinc.com)

# Regulatory Compliance

## Federal Communications Commission (FCC) / Industry Canada (IC)

### License Requirements

- Operation of the Transmitter requires a FCC/IC operating license, which must be obtained prior to operation.
- FCC licenses must be renewed every 10 years and the IC licenses must be renewed annually.
- As a service, Primex will file the license application if the end-user desires it. An end-user that does not want Primex to file for the original site license will be required to complete a waiver form, file the required application, and receive a valid license from the FCC/IC prior to use. If you have any questions or need any assistance, please contact Primex Technical Support.
- Primex requires a copy of the licenses in order to complete the factory presets.

### Product Compliance

- This device complies with Part 90 and Part 15 of the FCC rules and RSS-210 of Industry Canada.
- Operation of this device is subject to the following two conditions:
  1. This device may not cause harmful interference.
  2. This device must accept any interference, including interference that may cause undesired operation.

### Radio Frequency (RF) Exposure

To comply with FCC/IC RF exposure requirements for mobile transmitting devices, the Transmitter is only to be used or installed in locations where there are at least 20cm (approximately eight in.) separation distance between the antenna of the Transmitter and all persons.

# Important Safety Instructions

READ ALL INSTRUCTIONS BEFORE INSTALLATION, OPERATION, OR MAINTENANCE OF PRODUCT.

Some of the following information may not apply to your particular product model; however, as with any electronic product, precautions should be observed during installation, operation, and maintenance.

- Never operate the Transmitter without the antenna being properly connected to the Transmitter. Operating the Transmitter without an antenna can lead to permanent damage of the Transmitter and poses a safety risk.
- Do not touch any of the antennas while broadcasting.
- Standard acceptance procedures must be followed prior to operating this equipment in the proximity of life support systems.
- Do not operate the Transmitter outdoors, in wet areas where there is standing water, or in areas where there is condensation or the risk of condensation. Use in any of these environments will damage the Transmitter and void the warranty.
- Do not open the Transmitter to alter the internal elements in any way. This will void the warranty and could lead to unsafe conditions, malfunction, and violations of FCC/IC regulations.

Primex disclaims any liability or responsibility for the results of improper or unsafe installation practices.

# Contents

Specifications XR 1 Watt Transmitter - Internal Antenna	7
Transmitter Operation .....	7
XR 1 Watt Transmitter Specifications .....	8
GPS Receiver Specifications .....	10
Install XR 1 Watt Transmitter - Internal Antenna	11
Typical System Setup - 1 Watt Transmitter .....	11
Installation Overview .....	12
Tools and Equipment Required .....	12
Install Location Guidelines .....	13
Install GPS Receiver .....	13
Establish Transmitter Connections .....	16
Configure NTP Time .....	17
Set a Temporary IP Address for the Transmitter LAN Interface .....	21
Establish Transmitter Settings .....	23
Verify Transmitter is Operational .....	24
Transmitter Front Display	25
Transmitter Main Menu .....	26
Main Menu options .....	26
View Switch Settings .....	26
View GPS Setup Menu .....	27
View Diagnostics Menu .....	27
Identify Active Diagnostic Error Code .....	28
Diagnostic Error Codes Specifications .....	28
Clear Error Codes .....	29

Support	31
Five Year Limited Warranty	32

# Specifications XR 1 Watt Transmitter - Internal Antenna

Primex XR Series Transmitters use a 72MHz broadcast frequency to transmit a wireless radio frequency to seamlessly synchronize every clock independently to display the exact same time. Leveraging the precision of GPS satellite or Network Time Protocol (NTP) time, XR Series Transmitters wirelessly synchronize time for analog and digital clocks, timers and other time receivers throughout a facility.

## Transmitter Operation

### Time synchronization

Once a Transmitter has received its time, from either a GPS Receiver, NTP time source (XR models only) or another Transmitter, it sets its internal clock. It then transmits time information or schedules via a wireless radio frequency signal to the wireless clocks, bells, and other devices in the system. As a result, the system devices are precisely synchronized to each other and all time, schedules, and events are kept current.

Time Source: a Transmitter receives time from a GPS Receiver or a NTP server (XR models only) and then broadcasts received time and event schedules to clocks and other system devices.

Frequency and channel: a Transmitter operates on channels with 20kHz bandwidths and 72MHz frequency and is preset to one of the channels licensed by the FCC/IC to minimize interference on these frequencies and channels.

Broadcast (Transmit) Schedule Transmitter with Internal Antenna: broadcasts its synchronized time continuously to the system clocks and devices.

Analog Clock signal search frequency: six pre-scheduled times a day at 10:01, 2:01 and 6:01 a.m. and p.m. lock time (not the actual time of the day), a clock's receiver turns on to search for a Transmitter signal to receive a time update, starting with the previously stored channel number.

Digital Clock/Timer signal search frequency: every 10 minutes on the 5's (5, 15, 25, 35, 45, 55 minutes) of the hour, a clock's receiver turns on to search for a Transmitter signal to receive a time update.

---

### Power-up sequence

1. When the Transmitter is powered on, its front display lights up.
  2. Green, yellow, and red LED lights turn on for 2 seconds as a test and then turn off.
  3. Green LED illuminates to indicate the Transmitter is broadcasting.
  4. Front display initially displays the time as 12:00:00 and its software version.
  5. Transmitter checks the position of the switches on the back of the Transmitter, and stores the settings in its memory.
  6. Transmitter completes an initialization sequence with its time source. Its time source may be either a GPS Receiver, NTP, or Repeater (Satellite) Transmitter.
-

## Power failure

During a power failure, the Transmitter continues to track time with the last valid time signal that it received. Once the power had been restored, the Transmitter begins to broadcast (even without a valid time signal) to the down-stream components. Once the Transmitter has been powered on for a few hours, it's capable of keeping track of time off its internal backup power for up to eight hours.

- The system has a fail-safe design. If the failure of a system component or power loss to a component occurs, all down-stream components continue normal operations using their own internal time base.
- If after a specified period of time communication has not been restored, a visual indicator of a loss of communication appears and remains until communication is restored. Loss of communication visual indicators: Transmitter LED flashing, flashing colon on LED digital clocks/timers; stepping of second hand on analog clocks.

### NOTE

Transmitter with an External Antenna: In the event of a facility wide power outage, a Transmitter with an External Antenna will broadcast continuously for 8 hours upon the restoration of power, synchronizing all Primex devices throughout the facility.

In the event power to a Transmitter is shut off and turned back on (power cycled) the Transmitter will broadcast continuously for 8 hours. Power cycling the Transmitter can be used to set/reset system devices. It's not recommended to power-cycle a Transmitter when it is in an error status - indicated when its red LED is flashing.

## XR 1 Watt Transmitter Specifications

Parameter	Specification
Operating Frequency Range	72MHz
Channels	49 channels available (pre-programmed prior to shipping)
Dimensions	17 in. L x 12 in. W x 1.7 in. D (43.2 cm x 30.5 cm 4.32 cm)
Maximum Transmission	1 Watt (at Transmitter)
Radio Technology	Narrowband FM
Weight	9 lbs
Settings	Time Zone <ul style="list-style-type: none"><li>• LAN/Local, 30 min offset, serial/USB/Ethernet connectivity</li></ul>
Daylight Saving Time	Bypass switch



Parameter	Specification
Display	Liquid Crystal Display (LCD)
Power Supply	Input: 120 VAC, 50/60 Hz, 0.6 Amp Output: 9 VDC, 2.78 Amp 6 ft (1.82 m) cord
Operating Range	32° to 122° F (0° to 50° C), non-condensing environment

**NOTE**

Canadian Notice - Transmitter with an External Antenna: The manufacturer rated output power of this equipment is for single carrier operation. For situations when multiple carrier signals are present, the rating would have to be reduced by 3.5 dB, especially where the output signal is re-radiated and can cause interference to adjacent band users. This power reduction is to be by means of input power or gain reduction and not by an attenuator at the output of the device.

# GPS Receiver Specifications

A GPS Receiver draws time information from the U.S. Government Satellites, providing the system with Coordinated Universal Time (UTC).

- Mounted to rooftop, pole, or window (not a Low-E glass window).
- GPS Receiver sends UTC time to the Transmitter via the NMEA 0183 standard protocol.
- Optional GPS extension cable. A specially designed low-resistance cable to extend the distance between GPS Receiver and Transmitter. The maximum total length of the cable cannot exceed 200 ft. (60.96 m).

Parameter	Specification
Cable	10 ft. (3.05 m) cable  50, 100 and 200 ft. (15.24 m, 30.48 m and 60.69 m) extensions available. The maximum total length of the cable cannot exceed 200 ft. (60.96 m).
Dimensions	2.5 inches W x .75 inches H (6.35 cm x 1.91 cm)
Mounting Bracket	3.5 inches W x 1.4 inches H x 4.5 inches D (8.89 cm x 3.56 cm x 11.43 cm)  Included for rooftop or window installation.
Weight	0.75 lb (.34 kg)
Operating Range	-32° to 158° F (-30° to 70° C)

# Install XR 1 Watt Transmitter - Internal Antenna

Leveraging the precision of GPS satellite or Network Time Protocol (NTP) time, XR Series Transmitters wirelessly synchronize time for analog and digital clocks, timers and other satellite Transmitters throughout a facility. The Transmitter includes an external roof mounted antenna, which requires installation by a Primex Certified Installer.

Learn how to install and configure a XR 1 Watt Transmitter with an Internal Antenna.

## Typical System Setup - 1 Watt Transmitter

### Example: 1 Watt Transmitter with Internal Antenna and NTP Time Source

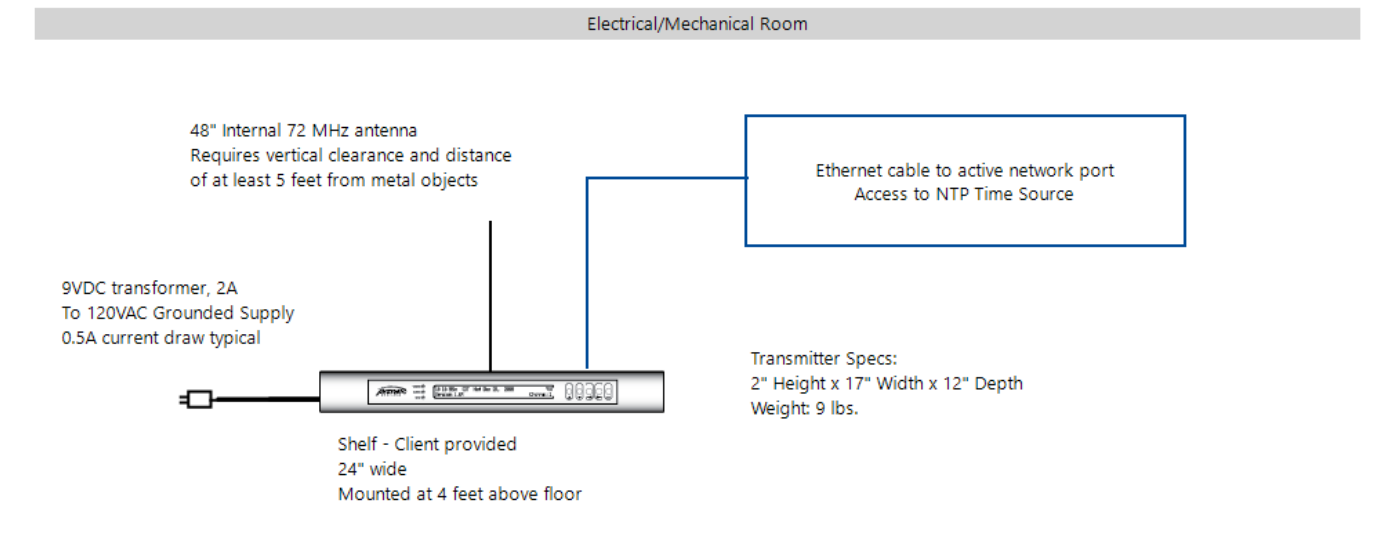

## Example: 1 Watt Transmitter with External Antenna and GPS Time Source

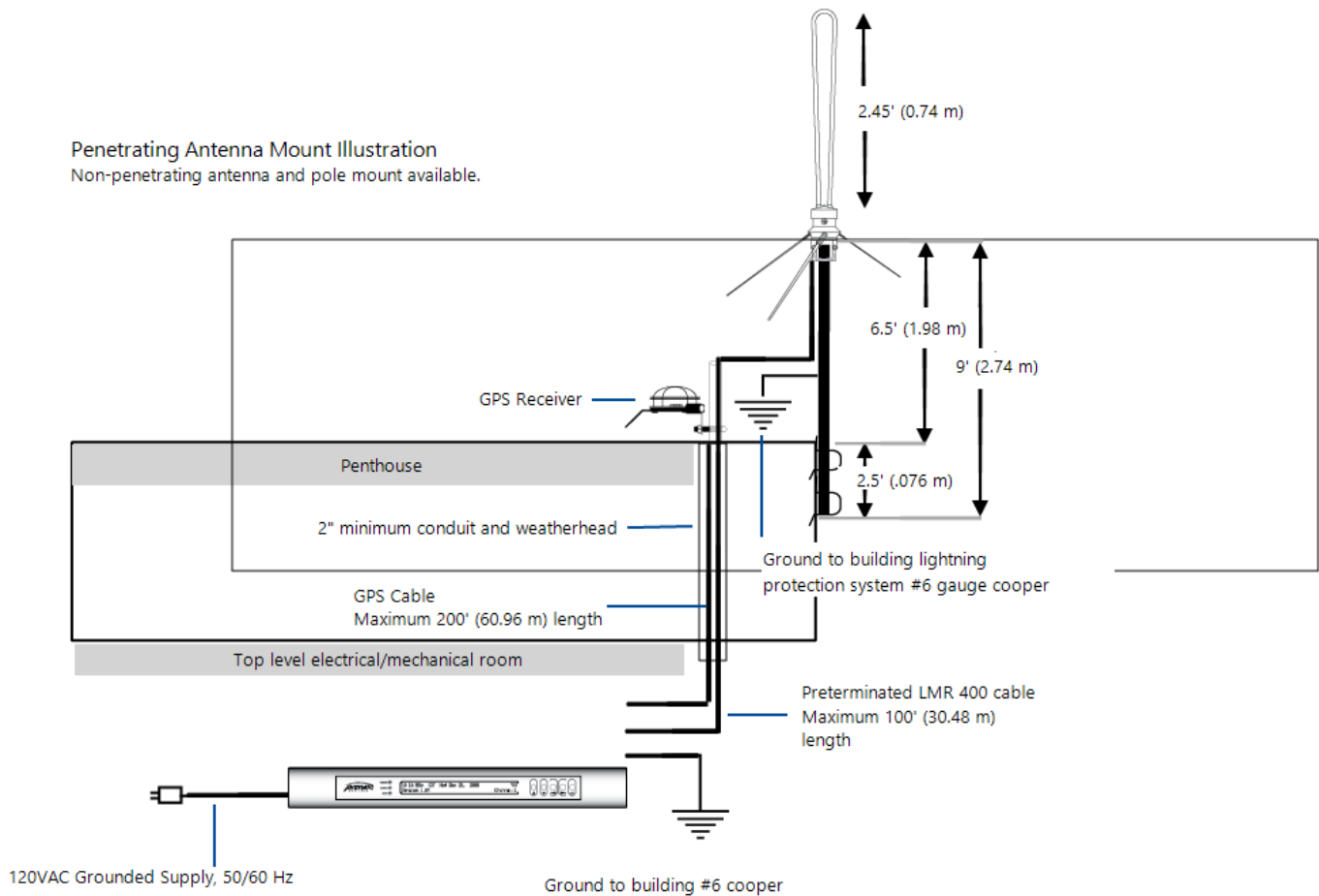

## Installation Overview

Listed below is the order the Transmitter and its components are to be installed and configured.

1. GPS time source: Install the GPS Receiver and route GPS cable.
2. Connect Transmitter antenna.
3. Connect Transmitter time source.
4. NTP time source: configure NTP time.
5. Establish Transmitter settings and verify connections.
6. Verify system is operational.

---

## Tools and Equipment Required

The following tools and equipment are required to complete installation.

---

## Transmitter equipment

- 1 Watt Transmitter Rack 18 GA metal, epoxy coated (optional)
- UPS surge protector and battery backup system (recommended)

## GPS Receiver installation tools and equipment

- Standard or hammer drill
- 5/8 inch concrete drill bit, 18 inches (45.7 cm) long
- Silicone caulk for GPS cable penetration
- Phillips screwdriver
- Flat head screwdriver

---

## Install Location Guidelines

When planning the system installation of a Transmitter with an Internal Antenna, Primex recommends taking into consideration the below guidelines. Location is extremely important to ensure the best operation of your system.

- In a multi-story building, locate Transmitter on the top floor; significantly improves coverage to the lower floors due to the “umbrella” pattern of transmission.
- Transmitter must be located a minimum of 4 feet (1.2 m) above the floor.
- Transmitter must be located within 5 feet (1.5 m) from a 120 VAC electrical outlet. 10 AMP dedicated service recommended.
- Transmitter 48" internal antenna requires vertical clearance and distance of a minimum 5 feet (1.5 m) from large, solid objects, such as lockers or filing cabinets, and cannot be touching any surfaces.
- Transmitter must be located in an area that allows for enclosure and antenna clearance. Enclosure dimension is 2" height x 17" width x 12" depth (5.08 cm x 43.18 cm x 30.48 cm) and antenna height is 48" (1.2 m).
- Transmitter must be located in a controlled environment that is 32° to 122° F (0° to 50° C) and non-condensing humidity environment.

---

## Install GPS Receiver

A GPS Receiver is required when a Transmitter is set to use GPS as its time source.

## Specifications

A GPS Receiver draws time information from the U.S. Government Satellites, providing the system with Coordinated Universal Time (UTC).

- Mounted to rooftop, pole, or window (not a Low-E glass window).
- GPS Receiver sends UTC time to the Transmitter via the NMEA 0183 standard protocol.
- Optional GPS extension cable. A specially designed low-resistance cable to extend the distance between GPS Receiver and Transmitter. The maximum total length of the cable cannot exceed 200 ft. (60.96 m).

Parameter	Specification
Cable	10 ft. (3.05 m) cable  50, 100 and 200 ft. (15.24 m, 30.48 m and 60.69 m) extensions available. The maximum total length of the cable cannot exceed 200 ft. (60.96 m).
Dimensions	2.5 inches W x .75 inches H (6.35 cm x 1.91 cm)
Mounting Bracket	3.5 inches W x 1.4 inches H x 4.5 inches D (8.89 cm x 3.56 cm x 11.43 cm)  Included for rooftop or window installation.
Weight	0.75 lb (.34 kg)
Operating Range	-32° to 158° F (-30° to 70° C)

## Installation location guidelines

Determine a suitable location for the GPS Receiver unit. Location is extremely important to ensure the best operation of the system.

- GPS Receiver must be mounted where it has a "clear view of the sky" to receive a GPS signal 24 hours a day.
- Typical mounting locations of the GPS Receiver unit include the inside of a window (not a Low-E glass window), to an exterior pole, or on a rooftop.
- GPS Receiver unit should be kept away from large metal objects.
- GPS Receiver unit and cable must be mounted above any potential standing water, snow depth, leaves or other obstructions and is protected from the weather.
- Maximum total distance of the GPS cable to the Transmitter cannot exceed 200 feet (60.96 m).
- If the GPS cable is located outdoors, the use of a GelWrap splice enclosure is strongly recommended.

## GPS Receiver mounting kit contents

Part	Quantity
Mounting bracket	1
GPS 18 LVC and connector	1
M3 x 0.5 x 6 mm pan head screws	2
#6 x 3/8 sheet metal screw	3

Part	Quantity
Suction cups	3
U-bolt with nuts for mounting on 1 inch (2.54 cm) pole	1

### How to mount a GPS Receiver

1. Verify the kit contents and the installation location meets the installation guidelines.
2. From the outside of the building, route the GPS cable.

Internal antenna Transmitter: route through a 5/8 inch drilled hole into the building.

3. Assemble and mount the GPS Receiver unit to either the inside of a window (not Low-E glass) or to an outside pole or rooftop. The mounting location is required to have a clear view of the sky.

#### NOTE

Be sure to follow local building code requirements when attaching the GPS unit to the inside of a window. Clean the windowpane before using the suction cups for attachment.

4. Route GPS cable and connect to Transmitter GPS connection.

1 Watt Transmitter: connect cable to the GPS IN connection.

5 or 30 Watt Transmitter: connect cable to the Transmitter exciter GPS IN connection.

---

## GPS Receiver installation components and illustration

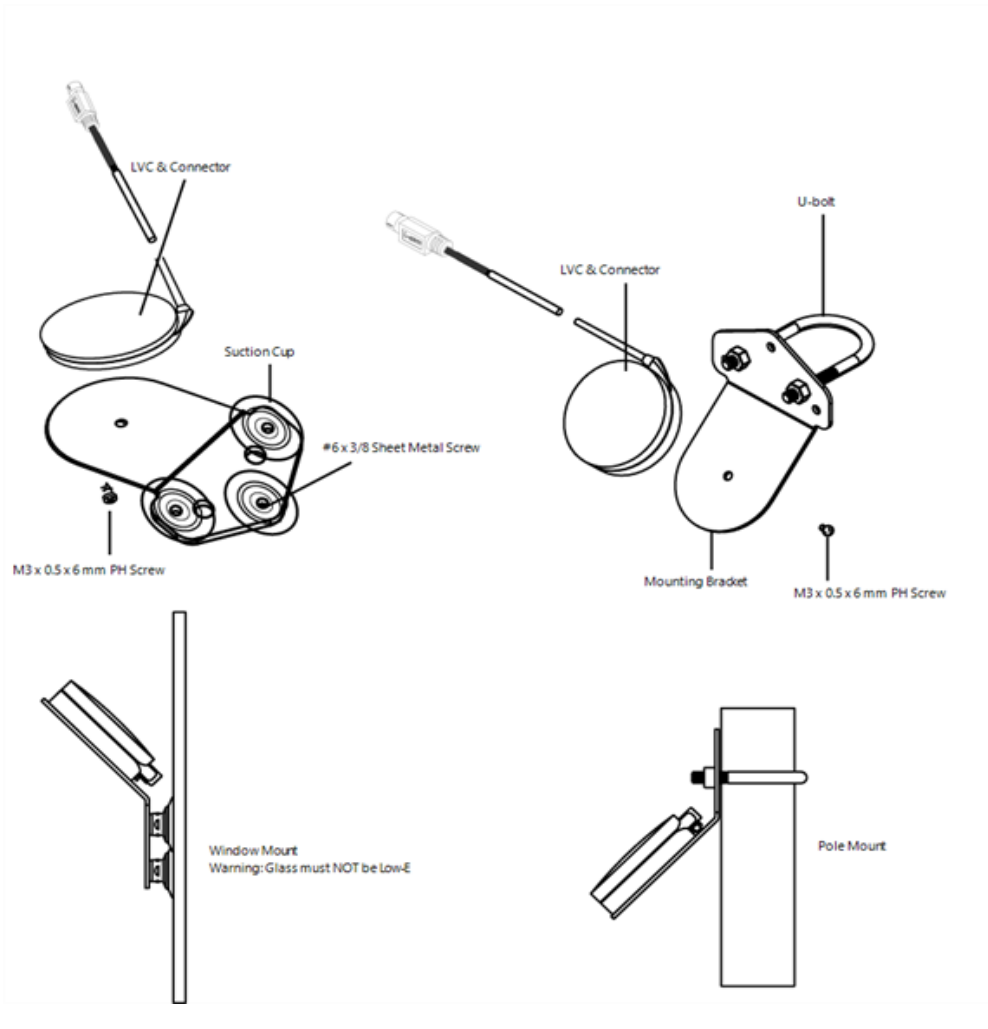

## Establish Transmitter Connections

### Internal antenna

The supplied antenna is attached onto the top case of the Transmitter.

Carefully screw the Transmitter antenna onto the Transmitter. Turn the antenna clockwise, being careful to avoid cross-threading the antenna. The antenna must be snug and flat against the case.

### Time source connection

The system can be configured to use GPS or NTP time.

- GPS: plug the supplied GPS cable into the Transmitter "GPS IN" connection.
- NTP time: connect a network cable to the Ethernet port/Network LAN connection and configure the Transmitter to use NTP time. To learn more, view "Configure NTP Time (Optional)" on page 1.

### 1 Watt Transmitter connection illustration



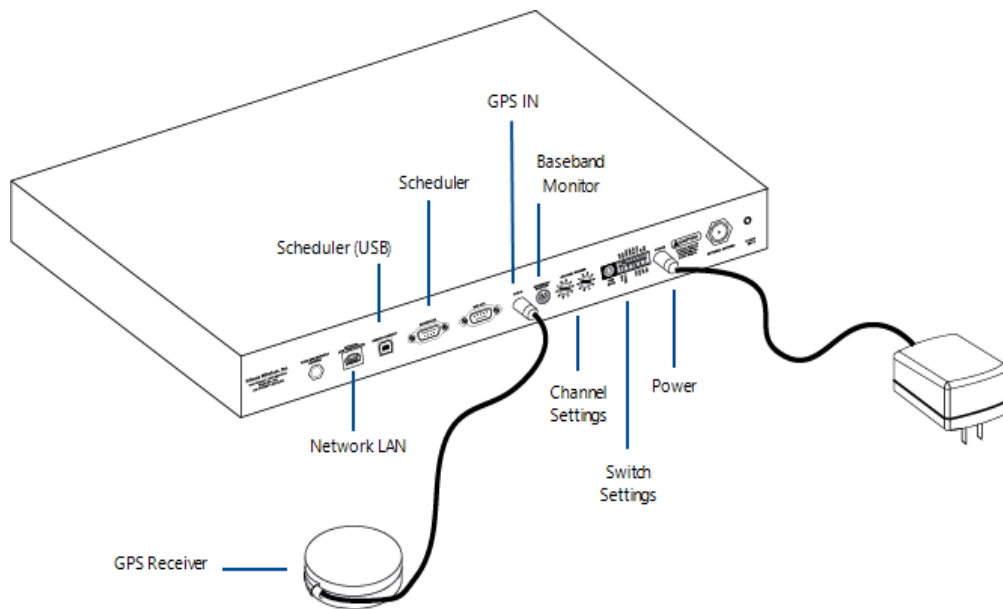

### Transmitter connection specifications

Connection	Type	Description
Network LAN	RJ-45 Ethernet	NTP time source
Scheduler USB (Server Connect)	USB Type B	Scheduler connection
Scheduler	Serial RS232 DB9, male	Scheduler connection
GPS IN	MiniDIN 7-Pin	GPS Receiver connection
Baseband Monitor	MiniDIN 9-Pin	Amplifier diagnostic connection
Power	9V DC power	AC-power connection

## Configure NTP Time

An XR Transmitter can be configured to use NTP as its time source. If the system will use NTP, complete the configuration procedures below.

### Overview

To use a NTP time source:

- Transmitter is required to be connected to a wired Ethernet network.
- Transmitter switch settings must be set for NTP time, which is specific to the transmitter's firmware version. The firmware version is displayed on the transmitter front LCD display in the lower-left corner. For version 1.79, set switch 1 to the UP position and switch 2 to the DOWN position. For versions below 1.79, set switch 1 and 2 to the UP position.
- Optionally can be configured to use an alternate NTP time source if the factory-default NIST time source will not be used.
- Transmitter NTP settings are accessed and configured from a web browser, use of Firefox is strongly recommended, on a computer that is on the same Local Area Network (LAN) as the Transmitter. If you need assistance, contact the on-site IT department.

#### NOTE

Prior to configuring the NTP time source, the IP address of the NTP server and Transmitter is required to complete this configuration. Before beginning this procedure set your computer to use a static IP address.

## Transmitter Factory Default Network Settings

- Factory-default IP address: 192.168.1.1
- Subnet mask: 255.255.255.0
- User name and password: blank (not required)
- Pre-Configured NTP Time Source: By default when configured for NTP time, the Transmitter is programmed from the factory to obtain the NTP time from the National Institute of Standards and Technology. According to the NIST they provide a public service by outputting one of two official time sources by the United States. Readings from the clocks of the NIST contribute to world time, called Coordinated Universal Time (UTC). The time maintained by NIST should never differ by more than 0.000 0001 seconds from UTC. For more information, please visit: <http://www.nist.gov>

#### NOTE

Be sure to write down and file all changes made to the network configuration settings. Once the default Transmitter static IP address is changed, the factory default IP address will no longer work and you must use the new IP address to access the Transmitter configuration.

## How to configure a Transmitter to use a NTP time source

1. Transmitter switch settings must be set for NTP time, which is specific to the transmitter's firmware version. The firmware version is displayed on the transmitter front LCD display in the lower-left corner. For version 1.79, set switch 1 to the UP position and switch 2 to the DOWN position. For versions below 1.79, set switch 1 and 2 to the UP position. Located on the back of the transmitter, set the dip switch settings to the firmware version.
2. Insert one end of an Ethernet cable into the Ethernet port located on the back of the Transmitter and the other end into a port on the facility's Ethernet network.
3. Apply power to the Transmitter.

- From your computer open a web browser, recommend use of Firefox is strongly recommended, and from the address bar enter the Transmitter factory default IP address: `http://192.168.1.1`

If the Transmitter IP address has been changed from the factory default address, complete the steps in topic [Set a Temporary IP Address for the Transmitter LAN Interface](#)

**NOTE**

Your computer is required to be on the same subnet as the Transmitter (for example: 192.168.1.10).

- The Connect To dialog window is displayed.



- Leave both user name and password blank, click OK to log into the Transmitter. The XPort Device Configuration Manager screen is displayed.



7. Click **Network**. The Network Settings screen is displayed.

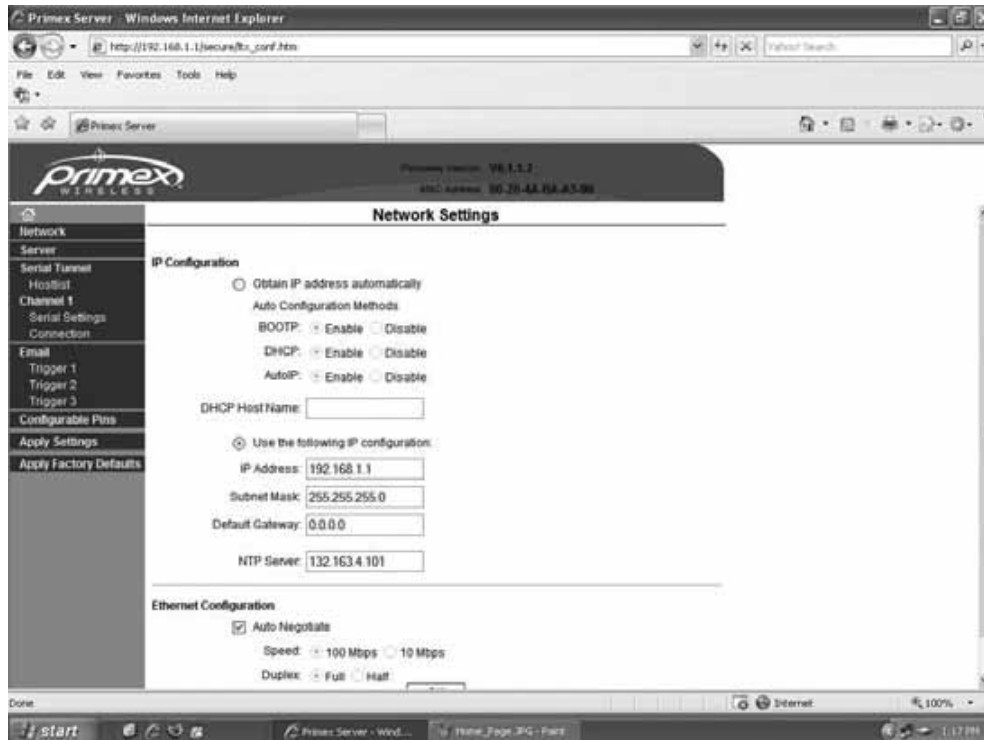

8. To change the factory default static IP address, set the options in the Network Settings screen.

- To use DHCP, select “Obtain IP address automatically”. You must also enter the DHCP Host Name.
- To use a static IP address, select “Use the following IP configuration” and enter the IP Address, Subnet Mask and Default Gateway.

## NOTE

Be sure to write down and file the changes you make to the network configuration settings. Once the default static IP address is changed, the factory-default IP address will no longer work and you must use the new settings to access the Transmitter configuration.

9. (Optional) Enter the IP address of the NTP server to set the Transmitter's time source.
10. Click OK.
11. Click Apply Settings on the configuration frame.

The Transmitter automatically reboots (restarts). The window below is displayed.



## Set a Temporary IP Address for the Transmitter LAN Interface

When configuring a Transmitter for NTP time and the IP address of the Transmitter is not known, you can assign a temporary IP address. Using the temporary IP address you can then access the Transmitter's network settings configuration screen to set the NTP time source. You may need to perform this procedure if you have forgotten the Transmitter's IP address or if the Transmitter is set to use DHCP.

## NOTE

The assigned temporary IP address used during this procedure is only accessible as long as the Transmitter is powered. If power is lost before the IP address is configured, you will need to repeat this procedure.

## How to set a temporary Transmitter IP address

1. On your laptop disable its wireless network connection. This ensures the laptop does not compete with any wireless networks in range when obtaining or assigning the temporary IP address.
2. Change the IP address of your laptop to a static IP address that is on the same subnet as the Transmitter. For example, if the Transmitter IP address will be 192.168.0.6, you can set the laptop's IP address to 192.168.0.2 with a subnet of 255.255.255.0.
3. Connect an Ethernet cable directly from your laptop's Ethernet port to the Transmitter's LAN port.
4. From your laptop, open a command window to set the temporary IP address for the Transmitter. To open the command window, select **Start > Run.** > from the run dialog, type **cmd** > click **OK**.
5. From the command window, enter the command below to assign a temporary IP address to the Transmitter.

```
arp -s xxx.xxx.xxx.xxx xx-xx-xx-xx-xx-xx
```

replacing xxx.xxx.xxx.xxx with the temporary IP address of the Transmitter and xx-xx-xx-xx-xx-xx with the MAC address of the Transmitter's LAN port.

For example, if you want to assign the temporary IP address 192.168.0.6 to a Transmitter with LAN port MAC address 00-20-4A-93-7F-D4, you would enter the command below:

```
arp -s 192.168.0.6 00-20-4A-93-7F-D4
```

### NOTE

If you do not know the MAC address of the Transmitter's LAN port, the MAC address is listed in the Transmitter's Diagnostics menu.

6. To complete assignment of the temporary IP address to the Transmitter, enter the below command into the command window:

```
telnet xxx.xxx.xxx.xxx 1
```

replacing xxx.xxx.xxx.xxx with the temporary IP address of the Transmitter.

In our example, you will type:

```
telnet 192.168.0.6 1
```

The telnet command will fail, ensuring the web connection will be available.

7. To verify the web connection is available, ping the Transmitter by entering the below command into the command window:

```
ping xxx.xxx.xxx.xxx
```

replacing xxx.xxx.xxx.xxx with the temporary IP address of the Transmitter.

If replies are received, you will be able to access the Transmitter through the web interface.

---

## Establish Transmitter Settings

The setting panel is located on the back of an XR Series Transmitter. The setting panel consists of dial and dip switch settings that set its channel number, time zone, and time source.

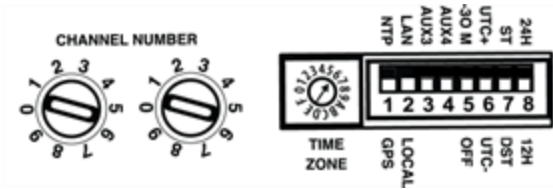

### Channel Number

Preset by factory. The Channel Number is set according to the FCC Site License; do not attempt to change without contacting Primex.

---

### Time Zone

- Transmitter with Internal Antenna: set the Time Zone dial to your system Time Zone using the dial Time Zone switch.

#### Time zone dial switch specifications

4 for Atlantic Time Zone

5 for Eastern Time Zone

6 for Central Time Zone

7 for Mountain Time Zone

8 for Pacific Time Zone

9 for Alaska Time Zone

A for Hawaii Time Zone

0 for Greenwich Mean Time (GMT)

---

### Time source and time settings

Set the Transmitter dip switch settings below to meet the system requirements.

Switch	Function	Up Position	Down Position
1	NTP/GPS	Receive time from NTP server.	Receive time from a GPS Receiver.
	Transmitter switch settings must be set for NTP time, which is specific to the transmitter's firmware version. The firmware version is displayed on the transmitter front LCD display in the lower-left corner. For version 1.79, set switch 1 to the UP position and switch 2 to the DOWN position. For versions below 1.79, set switch 1 and 2 to the UP position.		
2	LAN/Local	LAN network connection is enabled. Required for use of NTP time source.	Local USB and/or serial port attached to unit is enabled.
3	Aux 3 (setting unassigned)	Not applicable	Not applicable
4	Aux 4 (setting unassigned)	Not applicable	Not applicable
5	-30M	-30 minute offset enabled Transmitter is installed in Newfoundland or other countries with a -30 minute off set.	-30 minute off set disabled (default position)
6	UTC Offset	Transmitter is installed in Europe.	Transmitter is installed in North America
7	Daylight Saving Time	Daylight Saving Time is disabled.	Daylight Saving Time is enabled.
8	12-Hour or 24-Hour Time	Time is displayed in 24 hour time.	Time is displayed in a 12 hour time.

## Verify Transmitter is Operational

The final step is to verify the system Transmitter is operating and functional.

1. Verify a GPS signal or NTP time has been received.
2. Verify the time and date displayed on the Transmitter front display are correct.
3. Verify the Channel Number is set correctly.
4. Verify the Transmitter does not have any error codes. To learn more, view "View Diagnostics Menu" on page 27.



# Transmitter Front Display

The front LCD display of a XR Series Transmitter displays its current status, configured settings, and allows you to perform diagnostic tasks. The Transmitter's settings are configured from the setting panel located on the back of the unit.

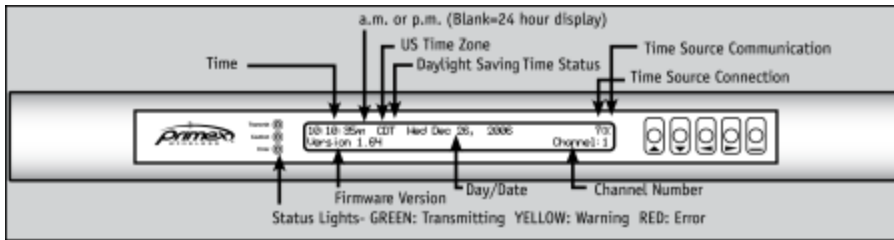



## Transmitter Main Menu

The front display Main Menu provides access to view the Transmitter's settings and diagnostic information.

The Main Menu is reached by pressing once on the  (right arrow) button.



To scroll down the Main Menu use the  button. If you scroll too far use the  (arrow up) button to go back.

---

## Main Menu options

**Switch Settings:** displays what the switch settings, located on the back of the unit, are set to. For detailed information, see topic [View Switch Settings](#)

**GPS Setup:** display is used to select the appropriate GPS Receiver. For detailed information, see topic [View GPS Setup Menu](#)

**Diagnostics:** displays the Transmitter's configuration information. For detailed information, see topic [View Diagnostics Menu](#)

**Diagnostic Error Code:** displays which error, if any, has occurred. For detailed information, see topic [Diagnostic Error Codes Specifications](#)

**Tech Support Info:** displays support contact information.

---

## View Switch Settings

The Main Menu Switch Settings selection provides the details of what the Transmitter dip switch settings, located on the back of the unit, are set to.

### How to access the Switch Settings menu

Move the selection arrow so that it is pointing to Switch Settings then press the  (right arrow) button once.



## Switch Settings information displayed

Channel Number: displays the Channel Number the Transmitter is broadcasting from per its FCC/ICC license.

Time Zone: displays the Time Zone.

ST/DST: displays whether or not Daylight Saving Time has been enabled.

24h/12h: displays the time option selected for the display.

UTC offset: displays the Time Zone location relative to Greenwich, England. (-) is west of England; (+) is East of England.

-30m/off: displays whether or not the -30m is enabled or disabled.

NTP/GPS: displays the time source input option selected (NTP or GPS).

LAN/Local: display whether the Transmitter's serial port is connected to a network port or locally.

Aux 3: future expansions.

Aux 4: future expansions.

## View GPS Setup Menu

Move the selection arrow so that it is pointing to GPS Setup, then press the  (right arrow) button once. This shows that the Transmitter has a port for a GPS 16 or 18.

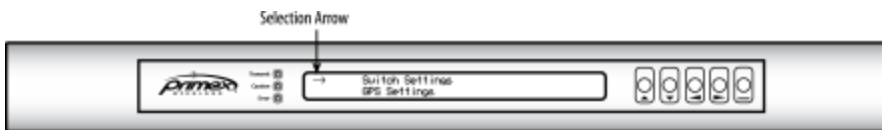

## View Diagnostics Menu

To view the Diagnostic Menu move the selection arrow so that it is pointing to Diagnostic, then press the  (right arrow) button once.



## Diagnostic menu specifications

There are seven entries that reflect the Transmitter configuration.

Firmware Rev: displays current version of software the Transmitter is running on.

Time Since Last GPS: displays how much time has passed since the Transmitter last received valid time from the GPS Receiver.

Hardware Rev: displays the hardware revision number

GPS/Repeater: displays if there is a GPS or a Repeater connected. If NTP is the time source, Repeater is displayed.

Last Repeater Update: displays how much time has passed since the Transmitter last received valid time from a Repeater Switch or NTP time.

Serial Number: displays the Transmitter serial number.

MAC Address: displays the device ID for the Network Interface.

---

## Identify Active Diagnostic Error Code

To identify the error code resulting in the red or yellow LED indicator, scroll to the entry that has a dot in front of it; which indicates that entry is the error.

When a Transmitter error code occurs, the yellow or red LED flashes and the error is logged. The LEDs continue to flash until all logged errors have been cleared.



### Diagnostic Error Codes definitions

Bad Output Power: indicates the Transmitter is not transmitting at the appropriate power level.

PLL Diagnostics: indicates the Transmitter is having trouble locking onto a channel; rendering it unable to broadcast time or schedules.

No GPS or Repeater Connected: indicates the Transmitter is not connected to a time source.

VSWR Errors: indicates there is a problem with either the High Power Antenna (may need repositioning) or the antenna cabling.

No GPS in 48 Hours: indicates the Transmitter has not synchronized to a time source for more than 48 hours.

No 1PPS in 48 Hours: indicates the time on the display has not been synchronized by 1PPS (1 Pulse Per Second) for more than 48 hours.

---

## Diagnostic Error Codes Specifications

There are six Diagnostic Error Codes that identify the cause of the error occurring.

## How to view Diagnostic Error Code(s)

1. Move the selection arrow so that it's pointing to the Diagnostic Error Codes, then press the  button once.



## Diagnostic Error Codes definitions

Bad Output Power: indicates the Transmitter is not transmitting at the appropriate power level.

PLL Diagnostics: indicates the Transmitter is having trouble locking onto a channel; rendering it unable to broadcast time or schedules.

No GPS or Repeater Connected: indicates the Transmitter is not connected to a time source.

VSWR Errors: indicates there is a problem with either the High Power Antenna (may need repositioning) or the antenna cabling.

No GPS in 48 Hours: indicates the Transmitter has not synchronized to a time source for more than 48 hours.





No 1PPS in 48 Hours: indicates the time on the display has not been synchronized by 1PPS (1 Pulse Per Second) for more than 48 hours.

---

## Clear Error Codes

Clearing a XR Transmitter error code stops the yellow and red LEDs from flashing.

### How to clear error codes

1. From the front panel, press right arrow  button once to access the Main Menu.
2. Use the down arrow button to select Diagnostic Error Codes, then press the right arrow  button once.
3. Use the down arrow button to scroll to the error, which is indicated by a preceding dot next to the error.
4. Press the right arrow  button once. The display will show when the error was logged. Note the time and data of the error.
5. Press the right arrow  button once.



6. Display will read: "Clear all errors?. Press the right arrow button once.
7. "Yes" and "No" are displayed with a selection arrow.

Selecting "Yes" followed by the pressing the ENTER button clears the errors.

Selecting "No" followed by pressing the ENTER button cancels the process and takes you back to the main menu.



8. Wait several seconds for the time/date to be displayed.

#### NOTE

If the LEDs continue to flash, repeat procedure as there may be additional errors to be cleared. If same errors continue to be logged, additional troubleshooting may be required. For further assistance, contact Primex Technical Support at 1-262-729-4860.

# Support

To obtain additional technical documentation for Primex products, visit the Support area on our website at [www.primexinc.com](http://www.primexinc.com)

You may require Technical Support when you have questions about product features, system configuration, or troubleshooting. Support services are delivered in accordance with your organization's support agreement, end user licenses agreements, and warranties, either with a Primex Certified Sales and Service Partner or directly with Primex.

## **Support through Primex Certified Sales and Service Partners**

Ensuring our customers experience excellent service is of utmost importance to Primex. Our network of Certified Sales and Service Partners offer technical support services for Primex products.

If you have purchased Primex products or have a service agreement with a Primex Partner, they are your primary contact for all Technical Support inquiries.

## **When contacting Primex Technical Support**

Make sure you have satisfied the system requirements listed in your product documentation. Also, you should be at the computer or device on which the problem occurred, in case it's necessary to replicate the problem.

When you contact Primex Technical Support, please have the following information available:

- Customer ID/Account Name
- Problem description/error messages
- Device hardware information
- Troubleshooting performed before contacting Primex

## **Primex Technical Support**

Hours: 8:00 a.m. to 5:00 p.m CST | Monday through Friday

Phone: 1-262-729-4860

Email: [techservices@primexinc.com](mailto:techservices@primexinc.com) | Web: [www.primexinc.com/support](http://www.primexinc.com/support)

---

## Five Year Limited Warranty

Primex, Inc. warrants this product to be free from defects in materials and workmanship for a standard of five (5) years from the date of purchase\* from an authorized reseller or directly from Primex. Primex, Inc. will at its sole option, repair or replace any components that fail in normal use. Such repairs or replacements will be made at no charge to the customer for replacement parts. The customer will be responsible for any transportation costs. This warranty does not cover failures due to misuse, abuse, accidental or unauthorized alterations or repairs.

The warranties and remedies contained herein are exclusive and in lieu of all other warranties express or implied or statutory, including any liability arising under any warranty or merchantability or fitness for a particular purpose, implied, statutory or otherwise. In no event shall Primex, Inc. be liable for any incidental, special, indirect or consequential damages, whether resulting from the use, misuse or inability to use this product or from defects in the product. Some states do not allow this exclusion or limitation of incidental or consequential damages so the above limitations or exclusion may not apply to you.

To obtain warranty service: If after following the instructions in the product guide, you are certain the product is defective, contact Primex Technical Support to assist with troubleshooting the issue. If the issue cannot successfully be resolved and the product is under warranty, a RMA (Return Material Authorization) will be generated. The RMA form will be provided via email with detailed instructions for the return. All merchandise returned must be shipped to Primex, Inc. Attn: Returns Dept., N3211 County Road H, Lake Geneva, WI 53147.

Primex, Inc. retains the exclusive right to repair or replace the unit at its sole discretion. Such shall be your sole exclusive remedy for any breach of warranty.

\* applies to products sold on or after June 1, 2018.