

Primex XR 72MHz Synchronized Time Solution

Repeater Transmitter Installation & User Guide



Legal Notice

Copyright ©2014 Primex, Inc. All rights reserved.

Printed in the USA.

Information in this document is subject to change without notice. Software described in this document is furnished under a license agreement or nondisclosure agreement. The software may be used or copied only in accordance with the terms of those agreements.

No part of this publication may be reproduced, stored in a retrieval system, or transmitted in any form or by any means, electronic, mechanical or otherwise, for any purpose, without the prior written permission of Primex, Inc.

Primex, Inc.

Primex is a leading provider of synchronized time and environmental monitoring solutions. Our solutions automate and maintain facility compliance, increase efficiencies, enhance safety and reduce risk for organizations in the healthcare, education, manufacturing and government vertical markets.

Worldwide Headquarters

965 Wells Street, Lake Geneva, WI 53147

Phone: 1-262-729-4853 | email: info@primexinc.com | www.primexinc.com

Regulatory Compliance

Federal Communications Commission (FCC) / Industry Canada (IC)

License Requirements

- Operation of the Transmitter requires a FCC/IC operating license, which must be obtained prior to operation.
- FCC licenses must be renewed every 10 years and the IC licenses must be renewed annually.
- As a service, Primex will file the license application if the end-user desires it. An end-user that does not want Primex to file for the original site license will be required to complete a waiver form, file the required application, and receive a valid license from the FCC/IC prior to use. If you have any questions or need any assistance, please contact Primex Technical Support.
- Primex requires a copy of the licenses in order to complete the factory presets.

Product Compliance

- This device complies with Part 90 and Part 15 of the FCC rules and of Industry Canada.
- Operation of this device is subject to the following two conditions:
 1. This device may not cause harmful interference.
 2. This device must accept any interference, including interference that may cause undesired operation.

Radio Frequency (RF) Exposure

To comply with FCC/IC RF exposure requirements for mobile transmitting devices, the Transmitter is only to be used or installed in locations where there are at least 20cm (approximately eight in.) separation distance between the antenna of the Transmitter and all persons.

Important Safety Instructions

READ ALL INSTRUCTIONS BEFORE INSTALLATION, OPERATION, OR MAINTENANCE OF PRODUCT.

Some of the following information may not apply to your particular product model; however, as with any electronic product, precautions should be observed during installation, operation, and maintenance.

- Never operate the Transmitter without the antenna being properly connected to the Transmitter. Operating the Transmitter without an antenna can lead to permanent damage of the Transmitter and poses a safety risk.
- Do not touch any of the antennas while broadcasting.
- Standard acceptance procedures must be followed prior to operating this equipment in the proximity of life support systems.
- Do not operate the Transmitter outdoors, in wet areas where there is standing water, or in areas where there is condensation or the risk of condensation. Use in any of these environments will damage the Transmitter and void the warranty.
- Do not open the Transmitter to alter the internal elements in any way. This will void the warranty and could lead to unsafe conditions, malfunction, and violations of FCC/IC regulations.

Primex disclaims any liability or responsibility for the results of improper or unsafe installation practices.

Contents

Specifications - XR Series Repeater (Satellite) Transmitter	6
XR Repeater (Satellite) Transmitter & Receiver Switch Specifications ..	6
Receiver Switch Specifications	7
Repeater (Satellite) Receiver Switch Specifications	7
Configure and Install	8
Verify Setup of Main Transmitter	8
Location Guidelines	8
Set Repeater (Satellite) Transmitter Preferences	9
Set Up Receiver Switch	11
Set Time, Date, and Channel Scan Settings	12
Receiver Switch - LED Status Indicator	12
Install Receiver Switch	14
Confirm Reception with Transmitter	15
Verify Receiver Switch Last Time Update	16
Receiver Switch Setting - Daylight Saving Time Not Observed	17
Set up Multiple XR Repeater (Satellite) Transmitters at the Same Facility	18
Support	19
Five Year Limited Warranty	20

Specifications - XR Series Repeater (Satellite) Transmitter

This section provides the specifications of the XR Series Repeater (Satellite) Transmitter and its system components.

Topics in this section include:

XR Repeater (Satellite) Transmitter & Receiver Switch Specifications

A XR Repeater (Satellite) Transmitter is an optional unit used with the XR Synchronized Time solution. The Transmitter is used to supplement and extend signal coverage and includes a Receiver Switch that receives a time signal from the Main Transmitter.

Parameter	Specification
Operating Frequency Range	72MHz
Channels	49 channels available (pre-programmed prior to shipping)
Dimensions	17 in. L x 12 in. W x 1.7 in. D (43.2 cm x 30.5 cm 4.32 cm)
Radio Technology	Narrowband FM
Weight	9 lbs
Settings	Time Zone <ul style="list-style-type: none">• LAN/Local, 30 min offset, serial/USB/Ethernet connectivity
Daylight Saving Time	Bypass switch
Display	Liquid Crystal Display (LCD)
Power Supply	Input: 120 VAC, 50/60 Hz, 0.6 Amp Output: 9 VDC, 2.78 Amp 6 ft (1.82 m) cord
Operating Range	32° to 122° F (0° to 50° C), non-condensing environment

NOTE

Canadian Notice - Transmitter with an External Antenna: The manufacturer rated output power of this equipment is for single carrier operation. For situations when multiple carrier signals are present, the rating would have to be reduced by 3.5 dB, especially where the output signal is re-radiated and can cause interference to adjacent band users. This power reduction is to be by means of input power or gain reduction and not by an attenuator at the output of the device.

Receiver Switch Specifications

Component	Specification
Cable	5 ft (1.52 m) RS232 cable connects Receiver Switch to the Repeater (Satellite) Transmitter
Dimensions	5.75 inches (14.6 cm) L x 4.25 inches (10.8 cm) H x 1.25" (3.16 cm) D
Antenna	12.5 inches (31.7 cm) L
Weight	0.75 lb (.34 kg)
Power Supply	Input: 120 VAC, 50/60 Hz, 0.4 Amp Output: 9 VDC, 0.25 Amp, 6 ft (1.83 m) cord
Operating Range	-32° to 58° F (-36° to 70° C)

Repeater (Satellite) Receiver Switch Specifications

Component	Specification
Cable	5 ft (1.52 m) RS232 cable connects Receiver Switch to the Repeater (Satellite) Transmitter
Dimensions	5.75 inches (14.6 cm) L x 4.25 inches (10.8 cm) H x 1.25" (3.16 cm) D
Antenna	12.5 inches (31.7 cm) L
Weight	0.75 lb (.34 kg)
Power Supply	Input: 120 VAC, 50/60 Hz, 0.4 Amp Output: 9 VDC, 0.25 Amp, 6 ft (1.83 m) cord
Operating Range	-32° to 58° F (-36° to 70° C)

Configure and Install

Topics in this section include:

Verify Setup of Main Transmitter

Installation of the Repeater (Satellite) Transmitter begins with the setup of the main Transmitter with a time source. The main Transmitter transmits the signal to the Repeater (Satellite) Transmitter by way of the Receiver Switch.

The main Transmitter must be set up and working prior to installation of the Repeater (Satellite) Transmitter. For the setup and installation of the main Transmitter, refer to the installation guide of the Transmitter model.

Location Guidelines

The Repeater (Satellite) Transmitter must be in a location where it can receive a signal from the Main Transmitter.

Typical Application Drawings

WARNING

Do not adjust the channel numbers on the Transmitter. The examples below only demonstrates how a repeater switch chain works.

Example of system with horizontal installation

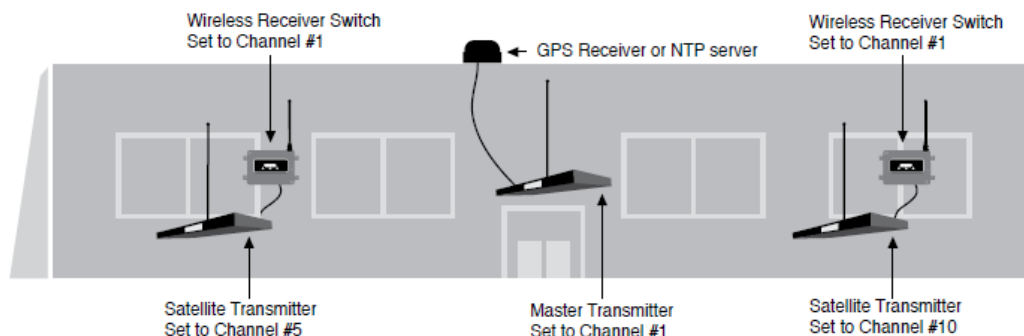

Example of a system with vertical installation

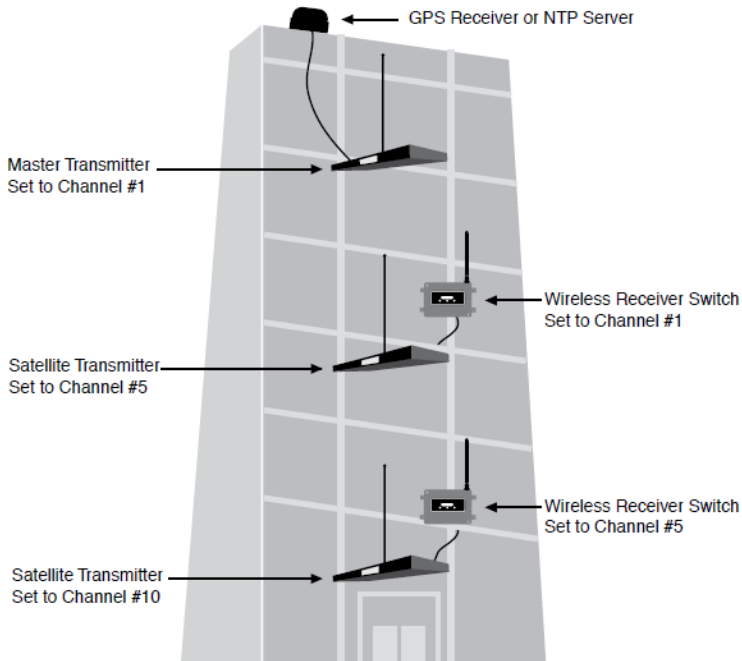

Set Repeater (Satellite) Transmitter Preferences

Model: XR Series Transmitter

Complete the steps below to set the preferences of a Repeater (Satellite) Transmitter. The setting panel is located on the back of the Transmitter unit.

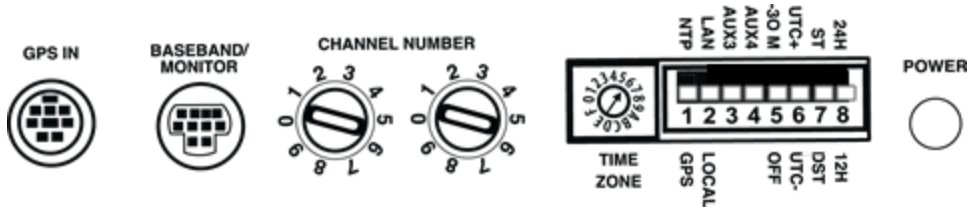

It's recommended to have a four channel separation between adjacent Transmitters.

WARNING

Do not adjust the channel number switches. They are only to be set to the frequency specified on the FCC/ IC application.

Set time zone

1. Set the Time Zone rotary switch for the correct Time Zone:
 - Turn to 4 for Atlantic Time Zone
 - Turn to 5 for Eastern Time Zone
 - Turn to 6 for Central Time Zone
 - Turn to 7 for Mountain Time Zone
 - Turn to 8 for Pacific Time Zone
 - Turn to 9 for Alaska Time Zone
 - Turn to A for Hawaii Time zone
 - Turn to 0 for Greenwich Mean Time (GMT)
2. Set Transmitter display time mode: set dip switch #8 to 12H or 24H
 - Flip switch to the UP position to select 24 hour time
 - Flip switch to the DOWN position to select 12 hour time
3. Set the Transmitter standard time: US:daylight saving timeUS: (ST/DST) preference. **set dip switch #7 to either ST/US: DST**
 - **Dip switch #7**US: (ST/DST) to the UP position. This will disable the US: Daylight Saving Time (DST) correction on the Repeater (Satellite) Transmitter. Where applicable, US: DST changes will be handled by the Receiver Switch. To learn more, view "Install Receiver Switch" on page 14.
4. Carefully screw the Repeater (Satellite) Transmitter antenna onto the unit. Turn the antenna clockwise being careful to avoid cross threading the antenna. The base of the antenna must be snug against the case.
5. Plug the supplied 9 Volt/2.78A Amp power supply into the Transmitter.
6. Plug the power supply into a 120 VAC outlet.

Satellite Transmitter backside connections

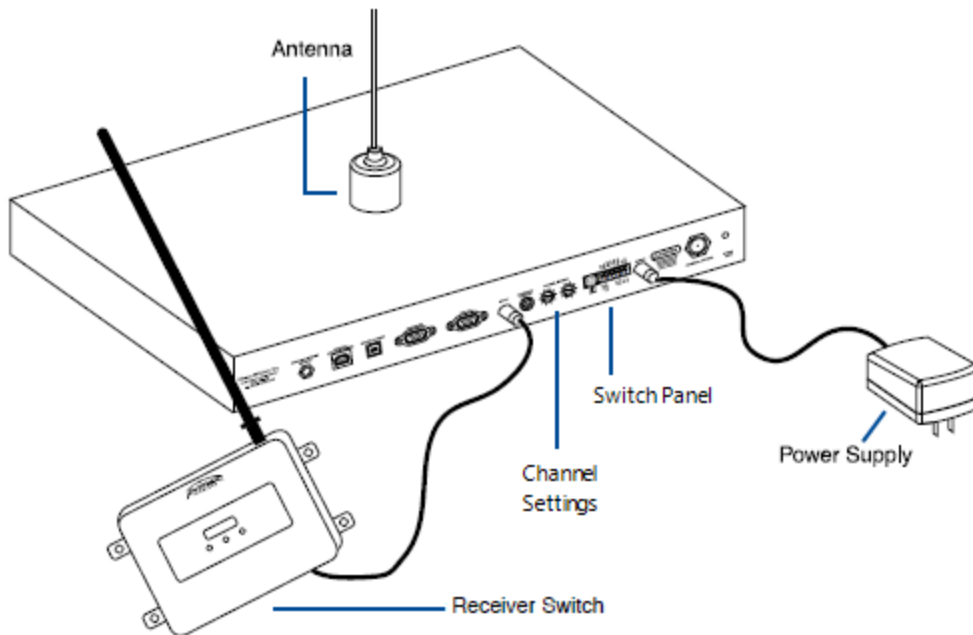

Set Up Receiver Switch

Model: Repeater (Satellite) Transmitter

To access the Receiver Switch menu preferences, press the Menu button located on the front of the unit. By pressing and holding the Menu button, the Receiver Switch cycles through the menu options.

- While in the Channel menu option if there are no changes made in a minute of entering a menu section, it will time out and save the displayed value and exit the menu mode.
- If a value is changed while cycling through the menu it will be saved and continue to cycle.
- While in test mode it will remain in the selected mode until the menu button is pressed again to exit.

After entering changes it's recommended to step through the menu options until the option donE is displayed to exit the menu mode; the menu will display donE. Changes made in the Menu are saved when the menu is exited.

Receiver Switch menu mode option specifications

Display	Menu	Description
Ch	Channel	The Channel Number menu allows the user to change the channel by using the UP or DOWN button. The channel number must be set to the same channel number as the Main Transmitter or other Repeater (Satellite) Transmitter broadcast channel.
tEst	Test	The Test menu allows the user to hear audible beeps with a valid time/date reception. This occurs 5 seconds after the test menu is selected. If continued to be in this mode until the menu button is pressed again, leaving the menu mode and returning to normal mode.
LtU	Last Time Update	The Last Time Update menu allows the user to see the last time update, time and date (cycles every second). This occurs five seconds after last time update menu is selected. The unit remains in this mode for a minute, it will then time out and return to the menu mode.
Soft	Software Revision	The Software Revision menu allows the user to see the software revision on the unit. This occurs five seconds after last time update menu is selected. The unit remains in this mode for a minute, it will time out and return to the menu mode.
dst	Daylight Saving Time Calendar	The Daylight Saving Time Calendar menu allows the user to see the current Daylight Saving Time calendar in use. This occurs five seconds after last time update menu is selected. The unit remains in this mode for a minute, it will time out and return to the menu mode.
donE	Done	The Done menu allows the user to exit the menu mode. This occurs five seconds after the done menu is selected returning to the normal mode and save all settings.

Set Time, Date, and Channel Scan Settings

The Receiver Switch has an internal dip switch panel that sets the configuration for the time/date display, automatic Daylight Saving Time, and automatic channel scanning.

To access the dip switch panel, remove the unit's large cover. Remove the switch cover by removing the two Phillip head screws, located in the upper left and lower right of the unit. The dip switch panel is located on the top of the unit; identified by the blue switch panel.

NOTE

Except when setting the dip switch options, the unit cover should remain closed and secure at all times.

Receiver Switch dip switch specifications

Switch	Sets the...	ON Position	OFF Position
2	Time/Date	displays only the time.	displays current time for 8 seconds and the date for 2 seconds.
3	12/24 Hour	displays the time in 24 hour format.	displays the time in 12 hour format.
4	RF Channel Scan	enable the scan and look for a suitable channel.	disable the scan and only look on the selected channel for time/date/event info.
5	US: Daylight Saving Time - DST	DST is disabled	DST is enabled.
6, 7, 8	Does not apply to the use of this unit.		

Receiver Switch - LED Status Indicator

The LED signal indicator (RX), located on the front right side of a Receiver Switch unit below the antenna, provides a visual indicator of its current operating status.

Green LED

- Flashes each time a transmitted signal is received by the Receiver Switch from the Transmitter at its update time.
- Will flash for 60 minutes when it has received a valid time update
- Will remain solid for 60 minutes if it has NOT received a valid time update.

Yellow LED

- Continues to flash if the unit goes 48 hours without receiving a time update.
-

Install Receiver Switch

1. Attach the rubber antenna to the Receiver Switch.

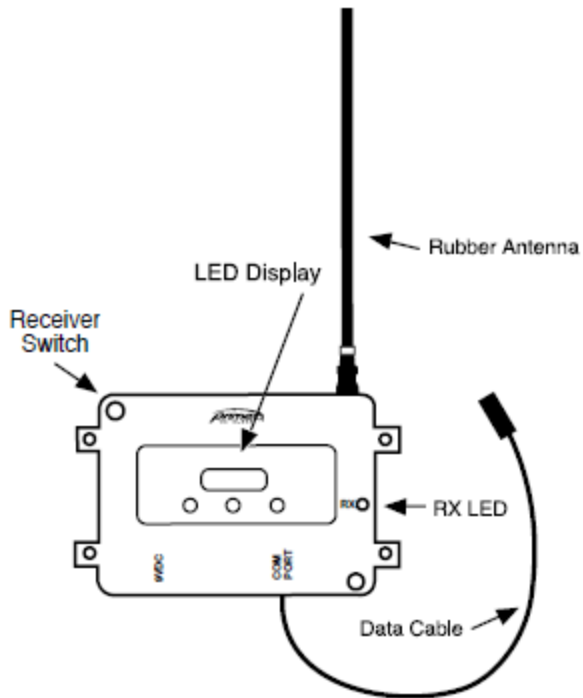

2. Power down the Repeater (Satellite) Transmitter.
3. Connect the serial cable of the Receiver Switch into the GPS IN Socket on the back of the Repeater (Satellite) Transmitter.

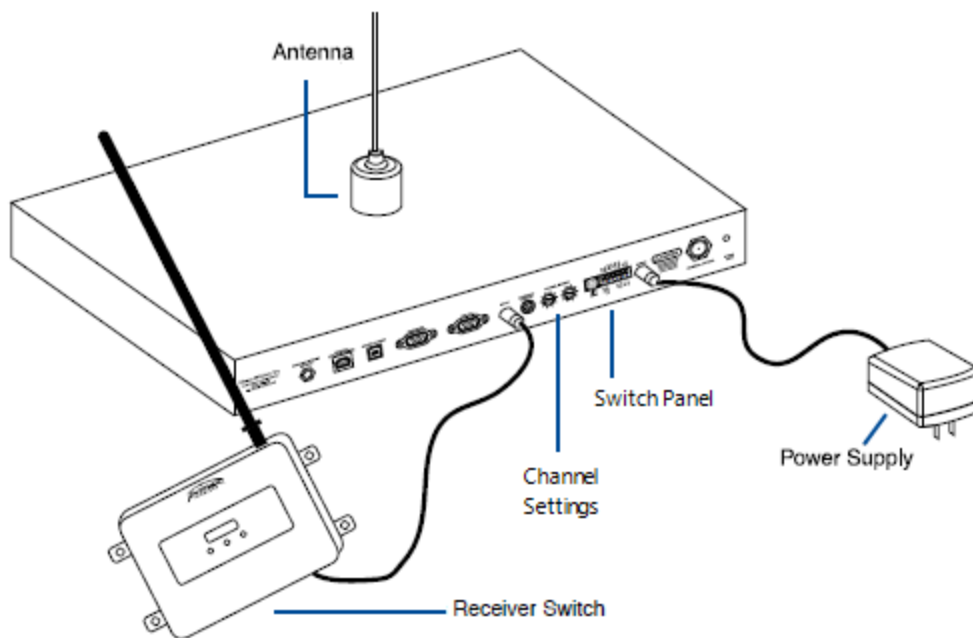

4. Power up the Repeater (Satellite) Transmitter.
5. Press the Menu (middle button) on the front of the unit to scroll through the Menu options to the Channel Mode (Ch displayed).
6. Press the UP or DOWN button to set the channel number to match the Main Transmitter's transmit channel.
7. Scroll through the menu to the donE mode. After 5 seconds the Receiver Switch will time-out and return to the Time/Date mode saving the channel selection.
8. Determine the best mounting location for the Receiver Switch.
 - a. Locate the room/area the Transmitter is to be installed in. Close all doors and windows before testing.
 - b. DO NOT hold the rubber antenna during testing, as this can affect the sensitivity of the receiver. Instead, hold the switch by the sides of the housing while locating the best mounting position.
 - c. Place the Receiver Switch in the EXACT location where it will be mounted. This is crucial as closeness to walls can degrade receiver sensitivity. If the exact location is not known, be sure to test the Receiver Switch in several locations. If any locations tested are unsuccessful, note this for future reference.
9. Power Cycle the Receiver Switch power at least 1 to 2 times after installation is complete and verify the green LED begins to flash. Doing this will ensure a solid signal is being received.
 - To power cycle the Receiver Switch, remove the switch cover by removing the two Phillip head screws located in the upper left and lower right of the unit. Use caution when removing the cover to avoid causing the up or down menu buttons to fall off the circuit board.
 - Press and release the Reset button, located in the upper right corner to the left of the antenna mounting, 1 to 2 times and verify the green LED begins to flash. The flashing of the green LED indicates a solid signal is being received.
10. Mount the Receiver Switch in its final location and verify the switch settings. To learn more, view "Set Up Receiver Switch" on page 11.

NOTE

When the Receiver Switch is mounted, its antenna must be vertical. Do not use an analog clock to determine if a mounting location will be adequate for signal reception. The receiver in a clock is more sensitive than the Receiver Switch and therefore the switch may not work in areas where a clock works.

Confirm Reception with Transmitter

When the Receiver Switch is connected to the powered Repeater (Satellite) Transmitter, an R is displayed in the upper right corner of the Transmitter's front panel display. This may take up to a minute.

The green RX LED on the Wireless Receiver Switch will flash when a valid signal is initially received. This LED will then flash once per second, signifying a successful time update. If the green LED is solid, the Receiver Switch missed the last update. Time updates occur once per hour.

NOTE

If the Repeater (Satellite) Transmitter does not receive a time update from the Receiver Switch after 48 hours, its yellow "Caution" LED begins flashing and an error is logged.

Verify Receiver Switch Last Time Update

To verify the last time the Receiver Switch received and applied a valid time/date update, toggle through the Receiver Switch Menu to the Last Time Update (LTU) section.

Receiver Switch Setting - Daylight Saving Time Not Observed

For geographic areas that do not observe Daylight Saving Time (DST), the Transmitter's Daylight Saving Bypass Receiver Switch must be configured to bypass DST as defined below.

NOTE

In the event the Receiver Switch does not receive a Transmitter signal when the DST change is scheduled to occur, the switch automatically adjusts its time received from a Transmitter. In areas that do not observe DST this feature must be disabled on the circuit board of the Receiver Switch as defined below.

How to set Receiver Switch not to observe DST

1. Disconnect the Receiver Switch from the Repeater (Satellite) Transmitter.
2. On the Receiver Switch remove the access cover and change dip switch #5 to the "ON" position.

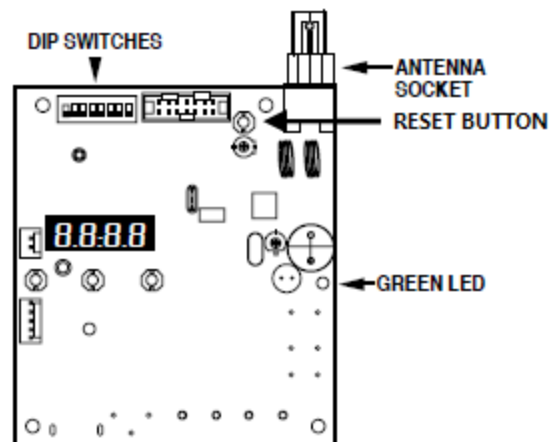

3. Reconnect Receiver Switch to Transmitter.

Set up Multiple XR Repeater (Satellite) Transmitters at the Same Facility

Set up and install each Repeater (Satellite) Transmitter and Receiver Switch. The channel number of the Repeater (Satellite) Transmitter is preset to the channel number specified on the red label located on the top its packaging box.

How to change a Receiver Switch channel number

1. Use the buttons on the Receiver Switch to toggle through to LED menu, and set the channel number to match the XR system channel with the strongest available signal. This signal may be from either the Main Transmitter or the nearest Repeater (Satellite) Transmitter.
 2. After changing the channel, power cycle the Receiver Switch. Remove the switch cover by removing the two Phillip head screws, located in the upper right and lower right of the unit. Use caution when removing the cover to avoid causing the up or down menu buttons to fall off the circuit board.
 3. Press and release the Reset button, located in the upper right corner to the left of the antenna mounting, one to two times and verify the green LED begins to flash. The flashing of the green LED indicates a solid signal is being received.
-

Support

To obtain additional technical documentation for Primex products, visit the Support area on our website at www.primexinc.com

You may require Technical Support when you have questions about product features, system configuration, or troubleshooting. Support services are delivered in accordance with your organization's support agreement, end user licenses agreements, and warranties, either with a Primex Certified Sales and Service Partner or directly with Primex.

Support through Primex Certified Sales and Service Partners

Ensuring our customers experience excellent service is of utmost importance to Primex. Our network of Certified Sales and Service Partners offer technical support services for Primex products.

If you have purchased Primex products or have a service agreement with a Primex Partner, they are your primary contact for all Technical Support inquiries.

When contacting Primex Technical Support

Make sure you have satisfied the system requirements listed in your product documentation. Also, you should be at the computer or device on which the problem occurred, in case it's necessary to replicate the problem.

When you contact Primex Technical Support, please have the following information available:

- Customer ID/Account Name
- Problem description/error messages
- Device hardware information
- Troubleshooting performed before contacting Primex

Primex Technical Support

Hours: 8:00 a.m. to 5:00 p.m CST | Monday through Friday

Phone: 1-262-729-4860

Email: techservices@primexinc.com | Web: www.primexinc.com/support

Five Year Limited Warranty

Primex, Inc. warrants this product to be free from defects in materials and workmanship for a standard of five (5) years from the date of purchase* from an authorized reseller or directly from Primex. Primex, Inc. will at its sole option, repair or replace any components that fail in normal use. Such repairs or replacements will be made at no charge to the customer for replacement parts. The customer will be responsible for any transportation costs. This warranty does not cover failures due to misuse, abuse, accidental or unauthorized alterations or repairs.

The warranties and remedies contained herein are exclusive and in lieu of all other warranties express or implied or statutory, including any liability arising under any warranty or merchantability or fitness for a particular purpose, implied, statutory or otherwise. In no event shall Primex, Inc. be liable for any incidental, special, indirect or consequential damages, whether resulting from the use, misuse or inability to use this product or from defects in the product. Some states do not allow this exclusion or limitation of incidental or consequential damages so the above limitations or exclusion may not apply to you.

To obtain warranty service: If after following the instructions in the product guide, you are certain the product is defective, contact Primex Technical Support to assist with troubleshooting the issue. If the issue cannot successfully be resolved and the product is under warranty, a RMA (Return Material Authorization) will be generated. The RMA form will be provided via email with detailed instructions for the return. All merchandise returned must be shipped to Primex, Inc. Attn: Returns Dept., N3211 County Road H, Lake Geneva, WI 53147.

Primex, Inc. retains the exclusive right to repair or replace the unit at its sole discretion. Such shall be your sole exclusive remedy for any breach of warranty.

* applies to products sold on or after June 1, 2018.